

Sheet: /  
File: stmbL\_4.0.sch

**Title:**

Size: A4 Date:  
KiCad E.D.A. kicad (5.0.0-rc2-dev-707-g2ed24a4)

Rev:  
Id: 1/14

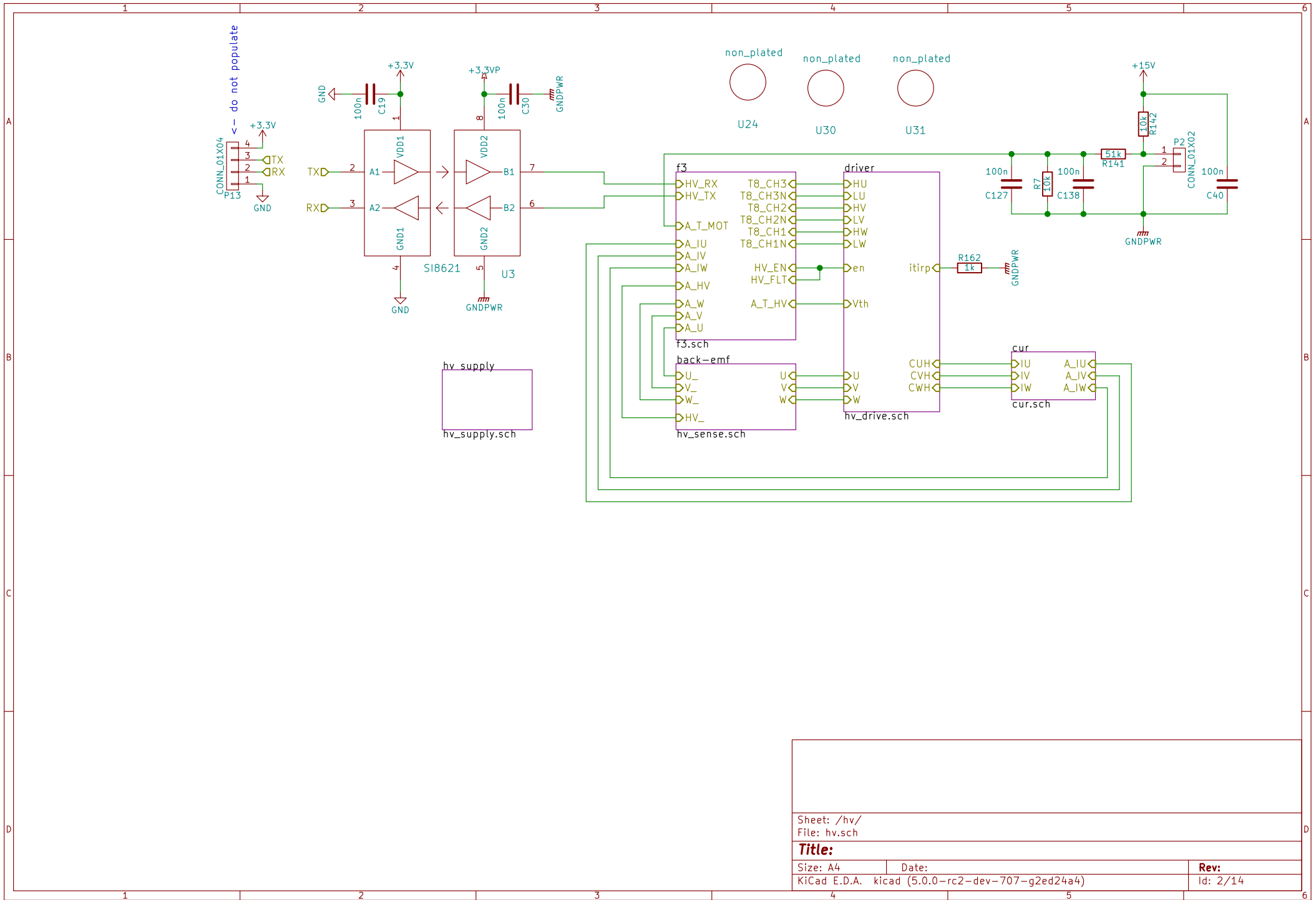

Sheet: /hv/	
File: hv.sch	
<b>Title:</b>	
Size: A4	Date:
KiCad E.D.A. kicad (5.0.0-rc2-dev-707-g2ed24a4)	
Rev:	Id: 2/14

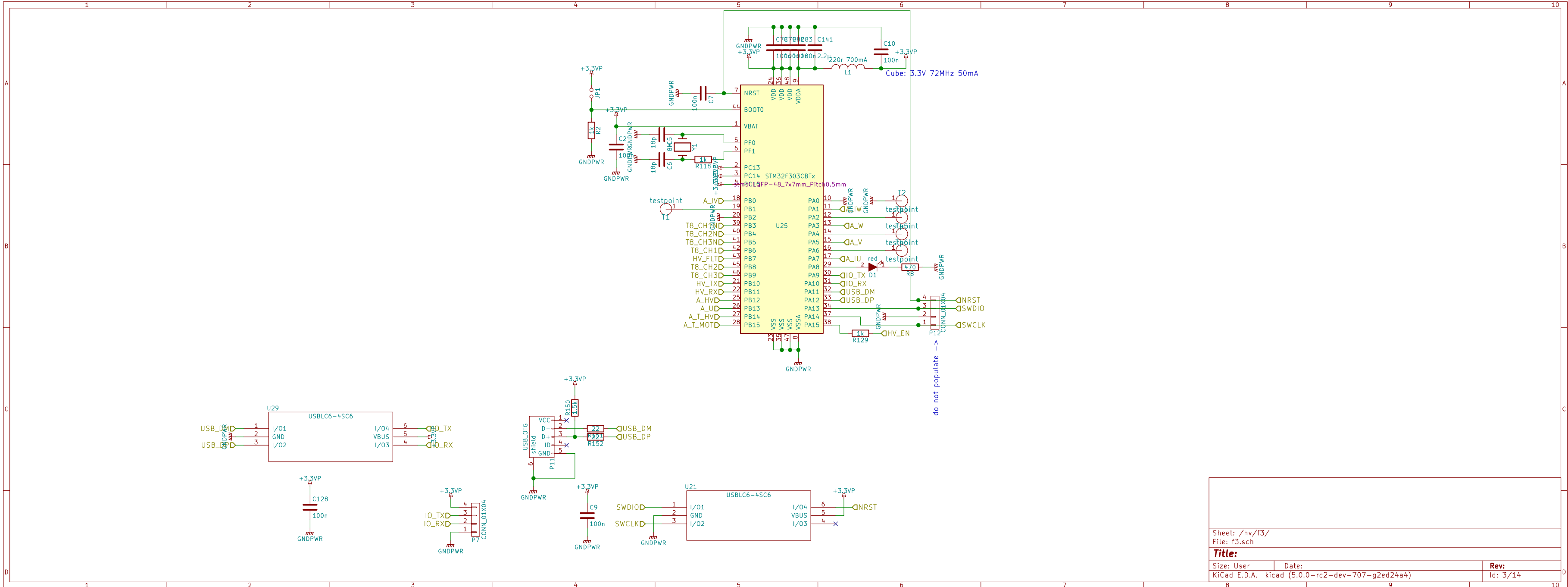

Sheet: /hv/f3/		
File: f3.sch		
<b>Title:</b>		
Size: User	Date:	Rev:
KiCad E.D.A. kicad (5.0.0-rc2-dev-707-g2ed24a4)		Id: 3/14

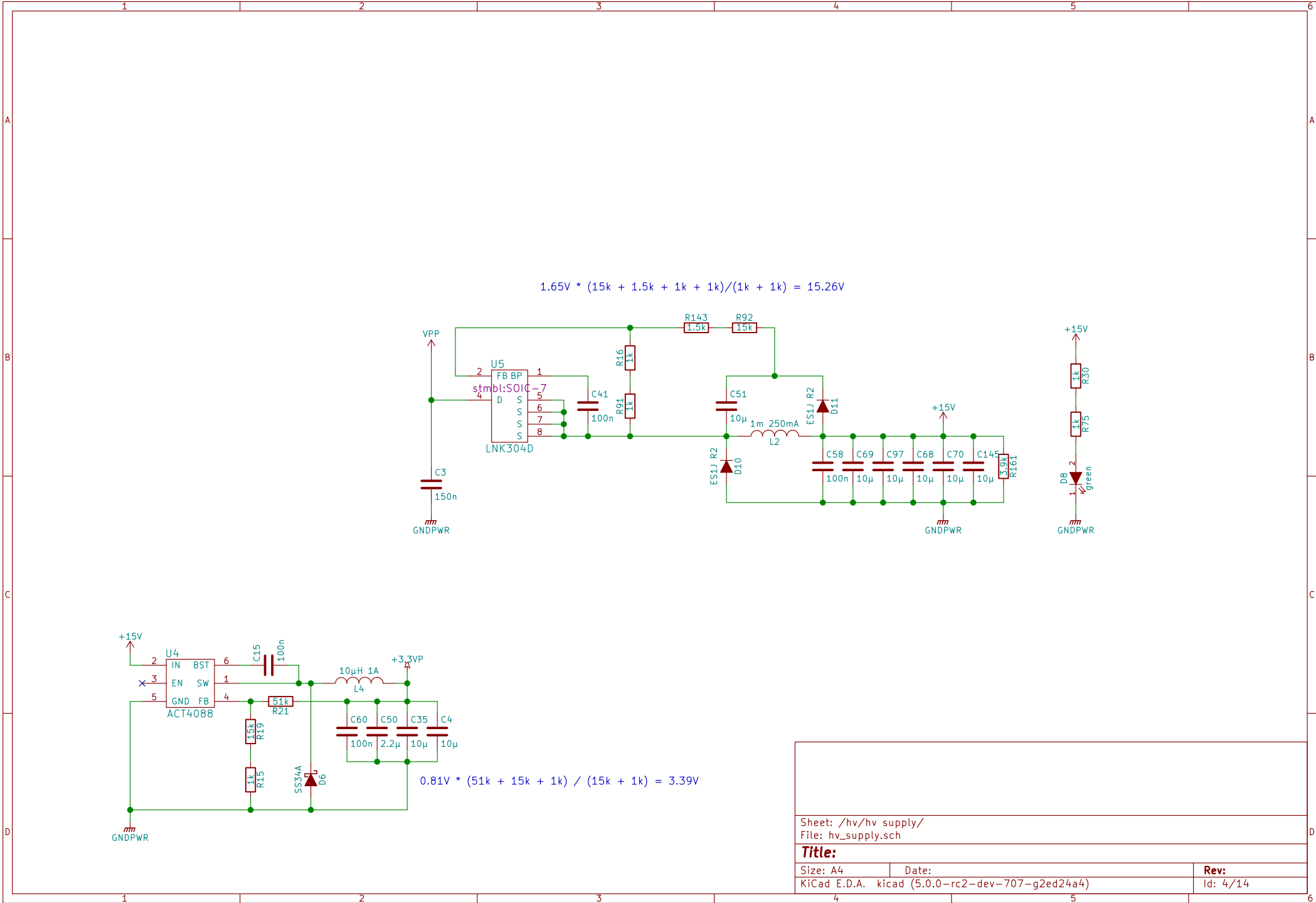

Sheet: /hv/hv supply/	
File: hv_supply.sch	
<b>Title:</b>	
Size: A4	Date:
KiCad E.D.A. kicad (5.0.0-rc2-dev-707-g2ed24a4)	
<b>Rev:</b>	
Id: 4/14	

$$3.3V * (249k + 249k + 3.9k) / 3.9k = 424V$$

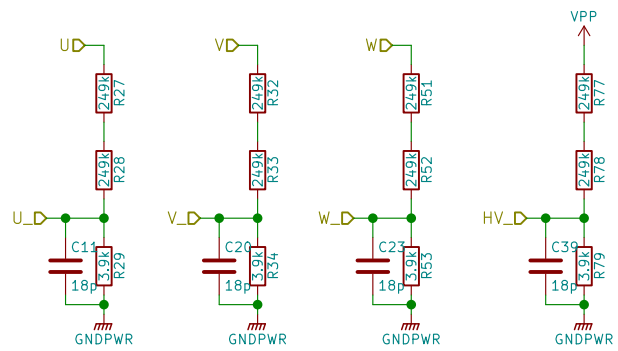

Sheet: /hv/back-emf/  
File: hv\_sense.sch

**Title:**

Size: A4      Date:  
KiCad E.D.A. kicad (5.0.0-rc2-dev-707-g2ed24a4)

**Rev:**  
Id: 5/14

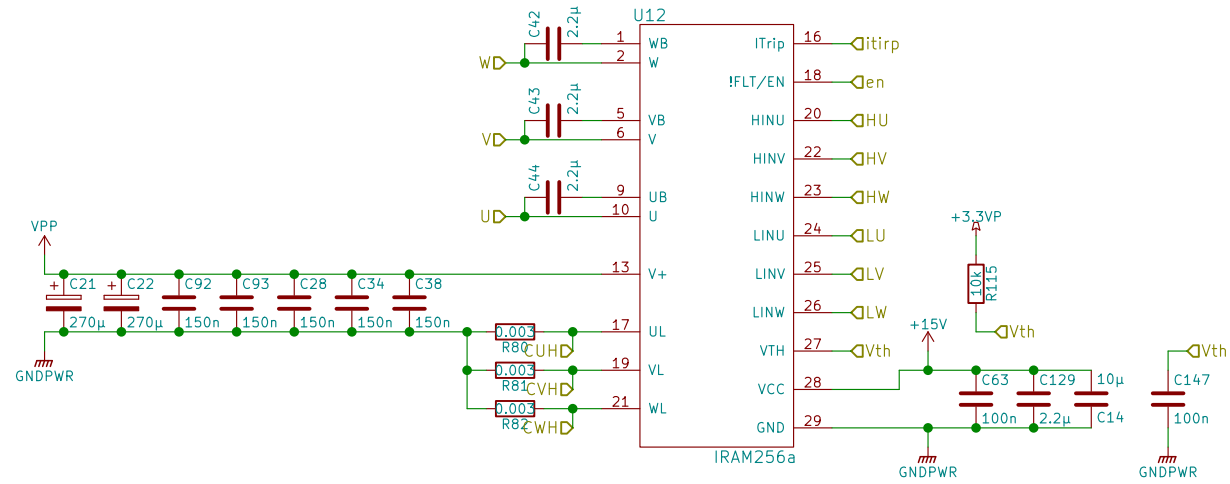
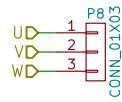
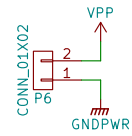

Sheet: /hv/driver/  
File: hv\_drive.sch

**Title:**

Size: A4 Date:  
KiCad E.D.A. kicad (5.0.0-rc2-dev-707-g2ed24a4)

**Rev:**  
Id: 6/14

+ -25A = 0.1V +-0.1V

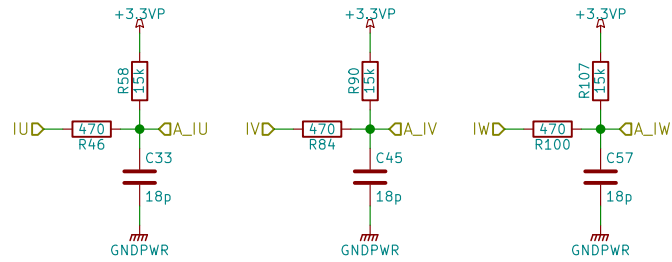

Sheet: /hv/cur/  
File: cur.sch

**Title:**

Size: A4 Date:  
KiCad E.D.A. kicad (5.0.0-rc2-dev-707-g2ed24a4)

Rev:  
Id: 7/14

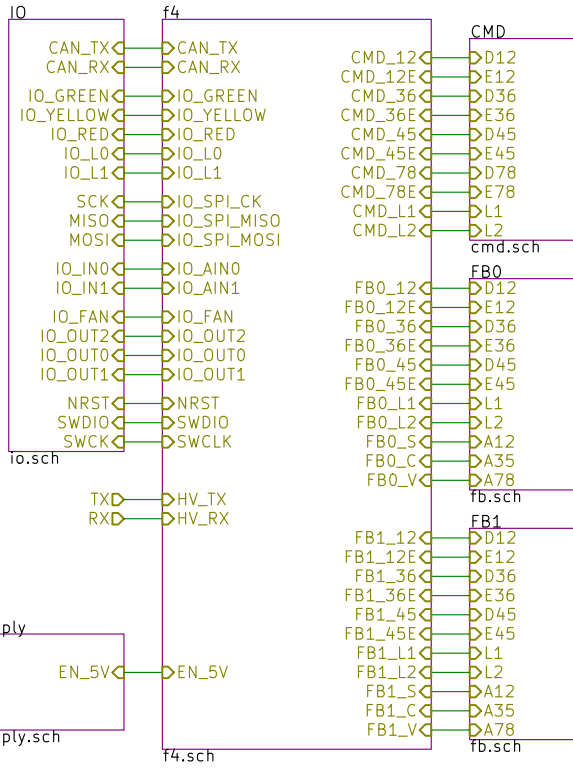
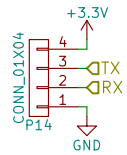

non\_plated



U32



Sheet: /ctrl/ File: ctrl.sch		
<b>Title:</b>		
Size: A4	Date:	Rev:
KiCad E.D.A. kicad (5.0.0-rc2-dev-707-g2ed24a4)		Id: 8/14



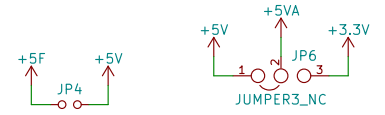
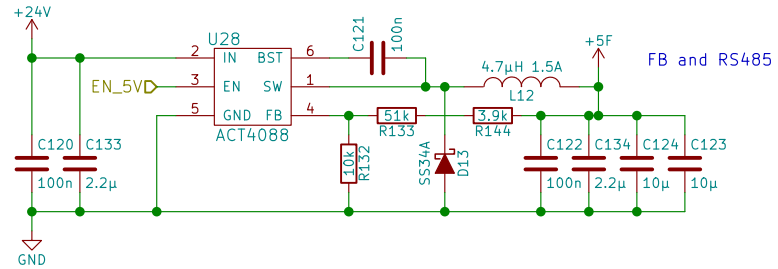
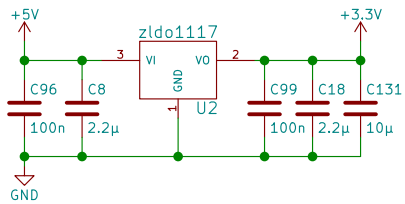
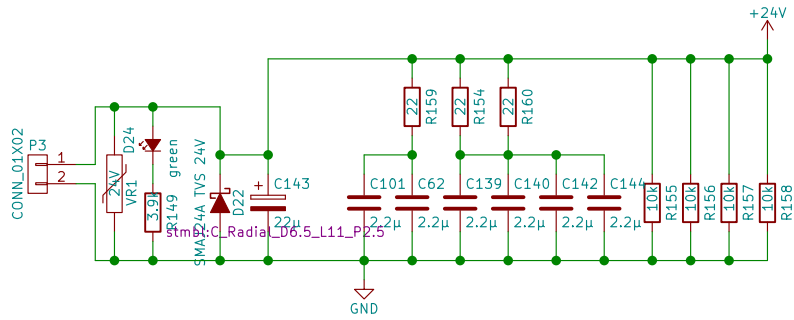

$$0.81V * (51k + 1k + 10k) / 10k = 5.02V$$

$$0.81V * (51k + 3.9k + 10k) / 10k = 5.25V$$

$$0.81V * (51k + 3.9k + 3.9k) / 3.9k = 12.21V$$

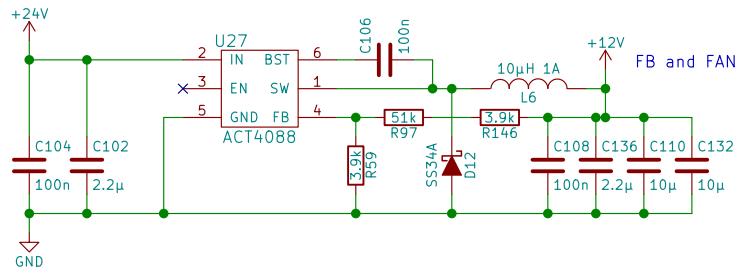
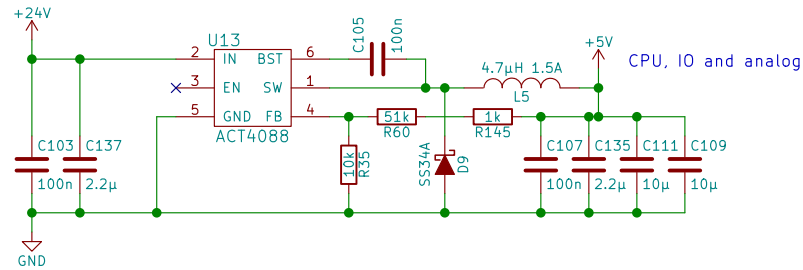

Sheet: /ctrl/supply/  
File: supply.sch

**Title:**

Size: A4 Date:  
KiCad E.D.A. kicad (5.0.0-rc2-dev-707-g2ed24a4)

Rev:  
Id: 9/14

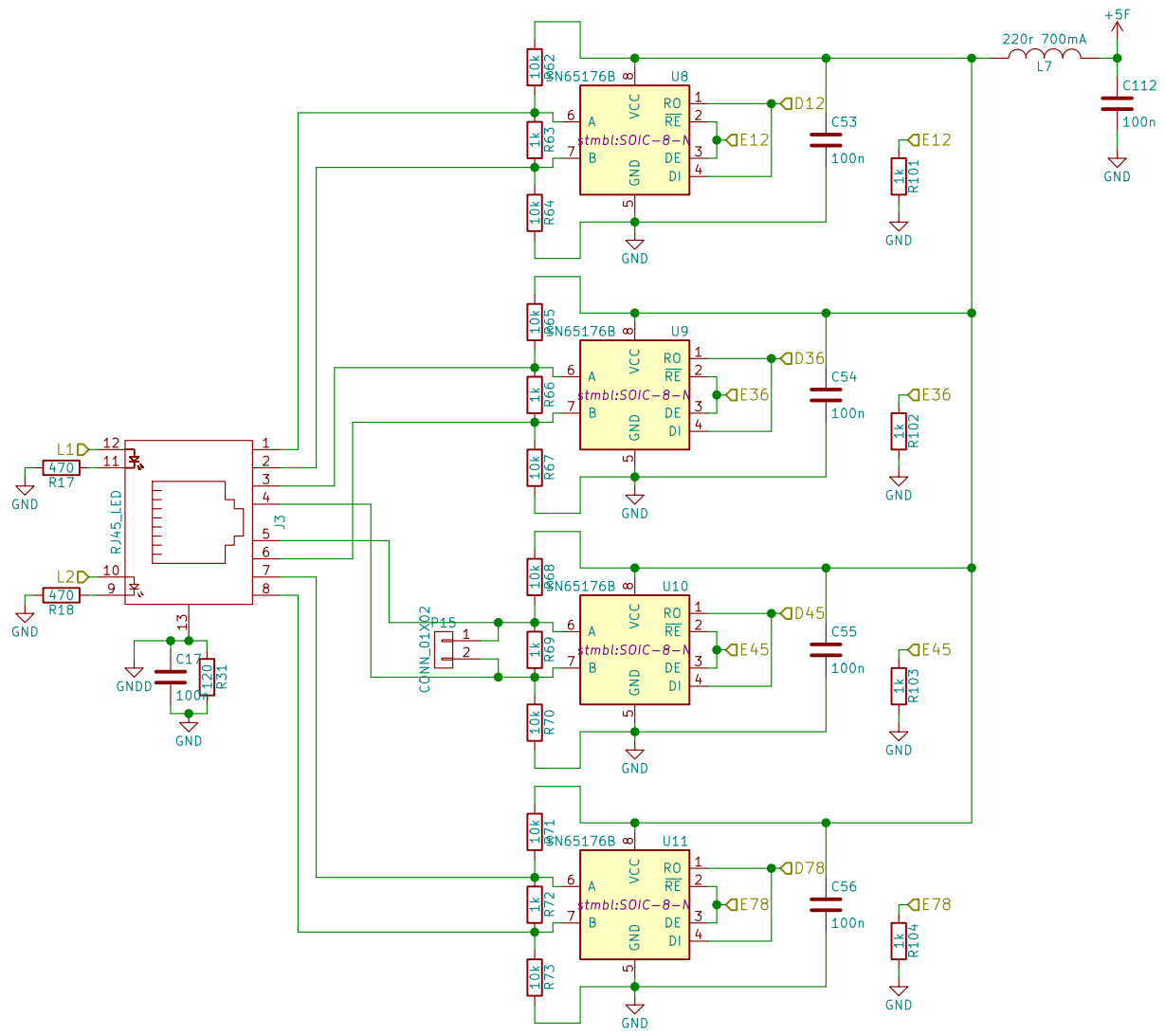

Sheet: /ctrl/CMD/  
 File: cmd.sch

<b>Title:</b>		<b>Rev:</b>
Size: A4	Date:	
KiCad E.D.A. kicad (5.0.0-rc2-dev-707-g2ed24a4)		Id: 10/14

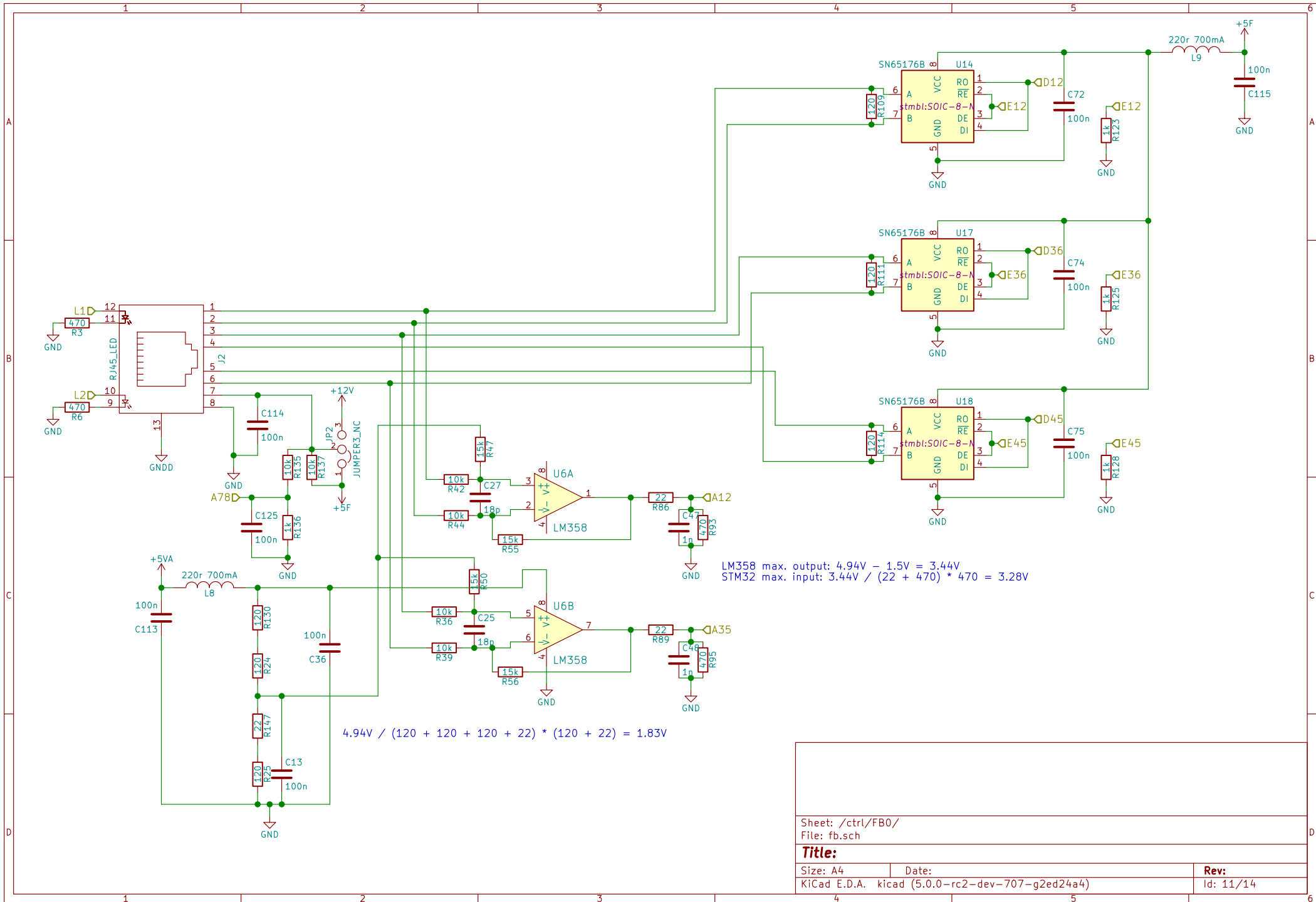

Sheet: /ctrl/FB0/		
File: fb.sch		
<b>Title:</b>		
Size: A4	Date:	Rev:
KiCad E.D.A. kicad (5.0.0-rc2-dev-707-g2ed24a4)		Id: 11/14

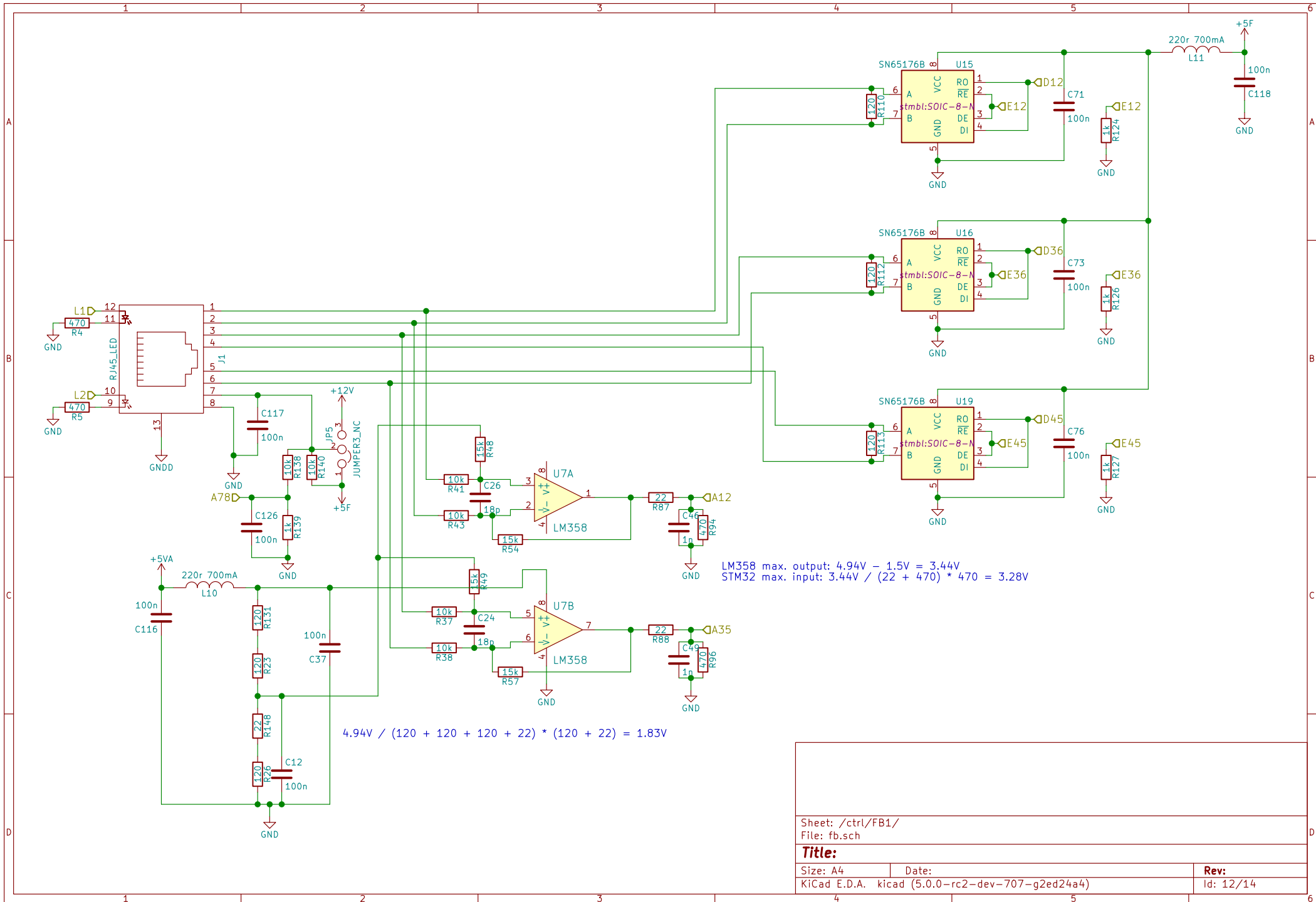

Sheet: /ctrl/FB1/  
 File: fb.sch

**Title:**

Size: A4  
 Date:  
 KiCad E.D.A. kicad (5.0.0-rc2-dev-707-g2ed24a4)

Rev:  
 Id: 12/14

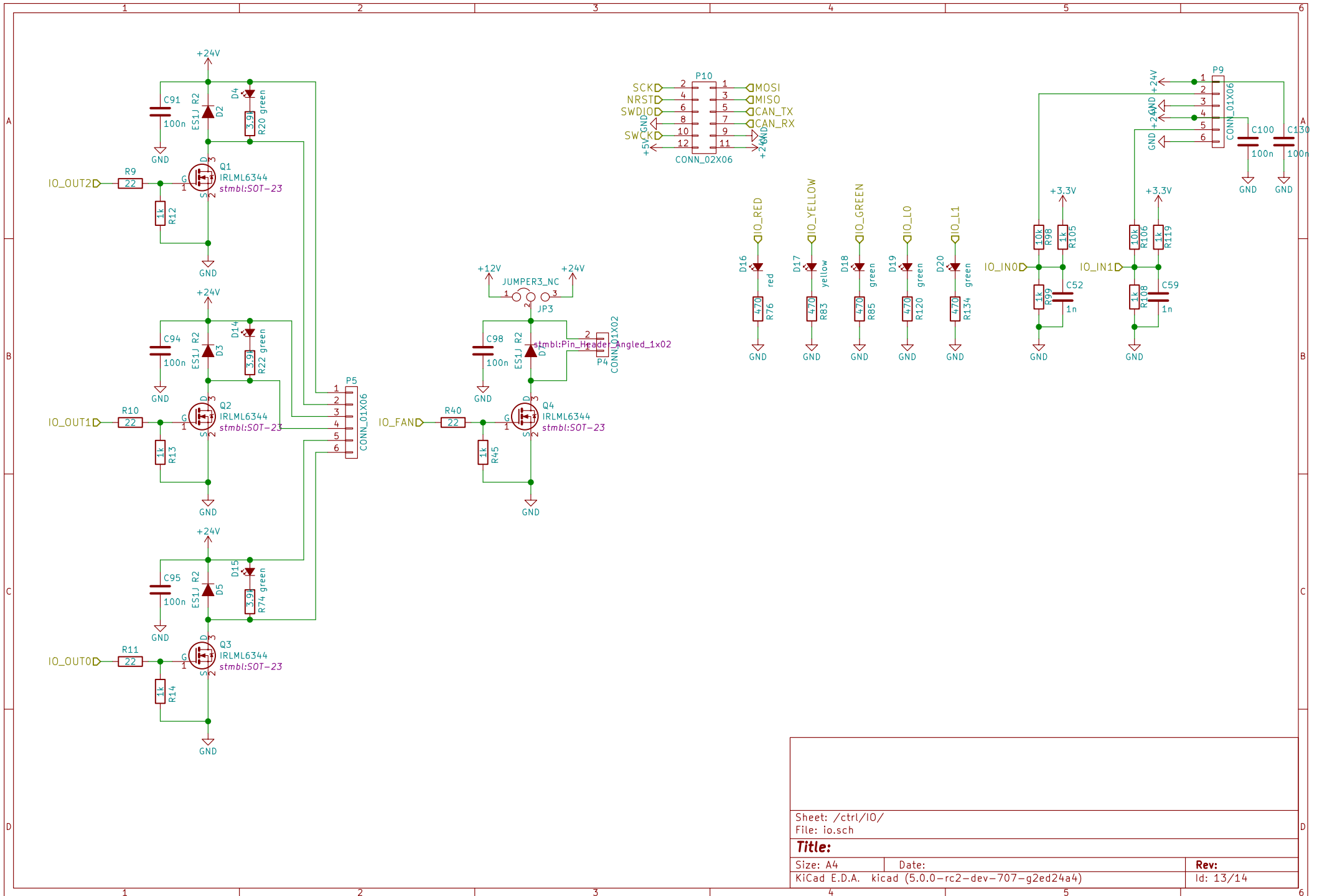

Sheet: /ctrl/IO/  
 File: io.sch

**Title:**

Size: A4  
 KiCad E.D.A. kicad (5.0.0-rc2-dev-707-g2ed24a4)

Date:

Rev:  
 Id: 13/14

